

CW86PH60

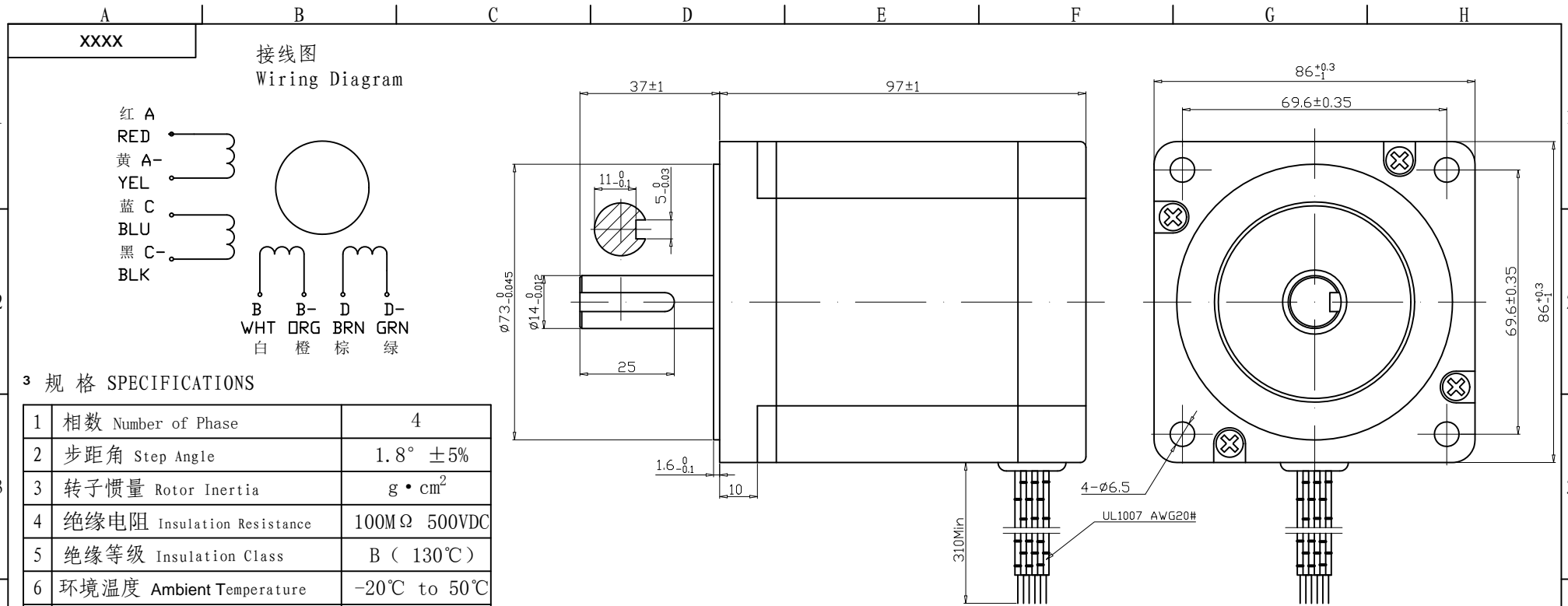

3 规格 SPECIFICATIONS

1	相数 Number of Phase	4
2	步距角 Step Angle	1.8° ±5%
3	转子惯量 Rotor Inertia	g · cm ²
4	绝缘电阻 Insulation Resistance	100MΩ 500VDC
5	绝缘等级 Insulation Class	B (130℃)
6	环境温度 Ambient Temperature	-20℃ to 50℃
7	环境湿度 Ambient Humidity	15% to 95%
8	电机重量 Motor Weight	Approx xx kg

	最大静转矩 Holding Torque (2 phases on) N.m±10%	额定电流/相 Rated Current/Phase (Amps DC)	相电阻 Resistance/Phase (ohms) ±10%	电压/相 Voltage/Phase (V DC)	电感/相 Inductance/Phase (mH) ±20% Typical (1kHz)
单极性驱动 Unipolar	4.6	4.2	1.2	5.0	3.4
串接 Bipoar (Series)	6.0	2.97	2.4	7.13	10.2
并接 Bipoar (Parallel)	6.0	5.94	0.6	3.6	2.7

3 WIRINGS CONNECTION DIAGRAM

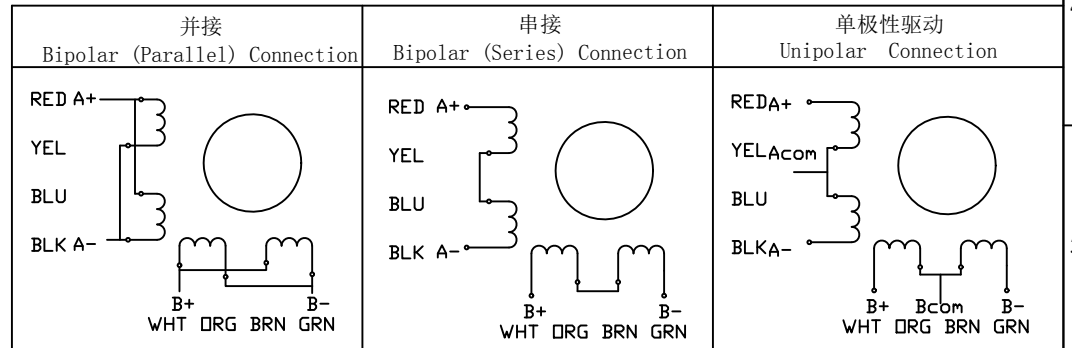

Unit:mm 第一角画法 First angle method 未注线性与角度尺寸公差 Tolerances for linear and angular dimensions without individual tolerance indications GB/T 1804-m eqv ISO 2768-1:m 未注形状与位置尺寸公差 Geometrical tolerances for features without individual tolerance indications GB/T 1184-k eqv ISO 2768-2:k	设计 DESIGN	XH	20190230	 WWW.CNCSANATJAHAN.COM 021-33932148 09101359566
	校核 CHECK			
	工艺 TECHNOLOGY			
	标准化 STANDARD			
	批准 APPROVE			
	NAMES	SINGATURE	DATE	
V1.0	HTPS1903141	20190320		
REV.	版本记录 REVISION RECORD	DATE	UNLESS OTHERWISE SPECIFIDE	