

[www.cnc24a2.com](http://www.cnc24a2.com)

# *Cable Chain Systems*

***FK SERIE***

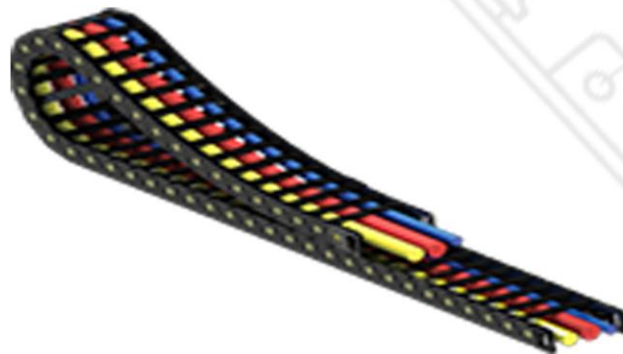

## Order Code :

**FK – 35 – A – 50 – R075**

Serie    Inner Height    Open Design    Inner Width    Bending Radius

## Material Properties :

PA66 with %30 fiber glass

## Application Areas :

,Gantry robot, Machining center  
,Textile machine Welding machine  
Feeder unit, Wood work machine  
Fabric machine

## Speed :

m/sec 10

## Operating Temperature :

C +- 150°C° -30

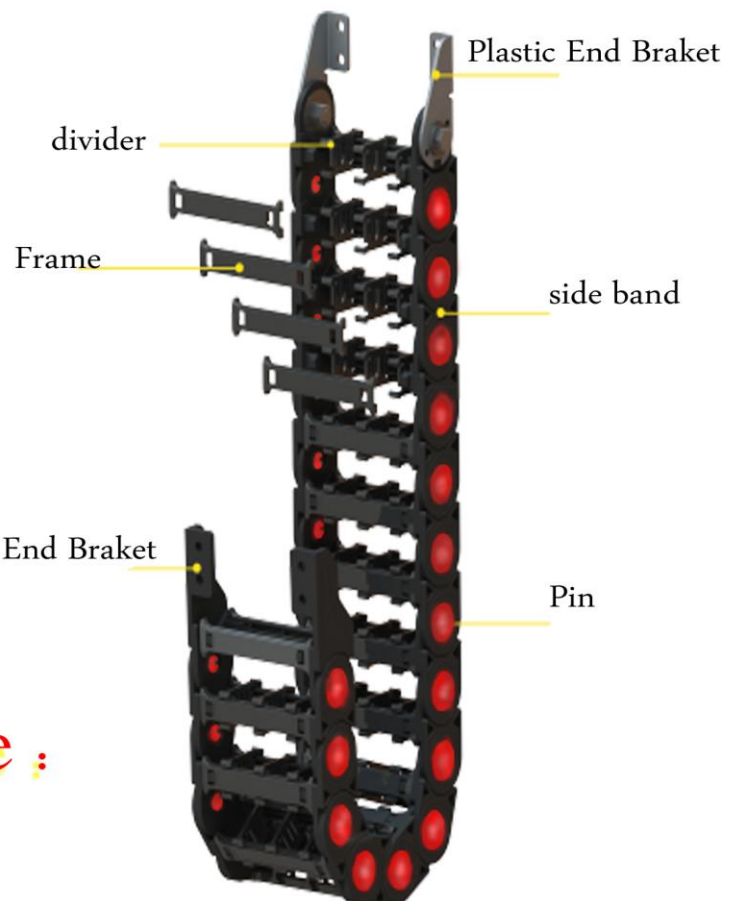

## L:

Calculation of the chain length

$$L = HM / 2 + Y$$

## HM:

Movement Distance

## Y:

Radius Distance

$$Y = R * 3.14$$

## X:

Mounting Height

$$X = R * 2 + C$$

## H:

Pitch

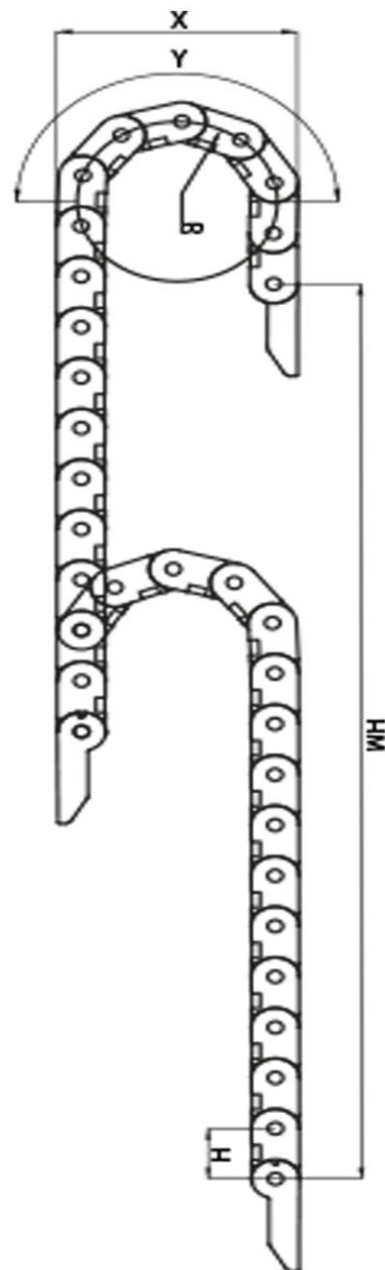

R Bending Radius	50	75	100	150
H (mm)	52	52	52	52
X (mm)	152	202	252	352
Y (mm)	157	236	314	471

	A	B	C	D	W
MODEL	Inner Height (mm)	Inner Width (mm)	Outer Height (mm)	Outer Width (mm)	Weight Kg/Mt
CK35 A 040 R	35	40	52	64	1,45
CK35 A 060 R		60		84	1,63
CK35 A 080 R		80		104	1,76
CK35 A 100 R		100		124	1,80
CK35 A 125 R		125		149	2,02

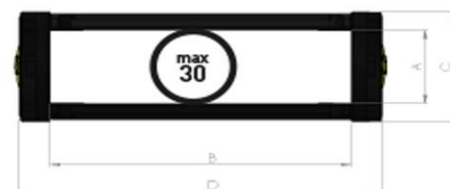

02133531249

## Chain Cross Section :

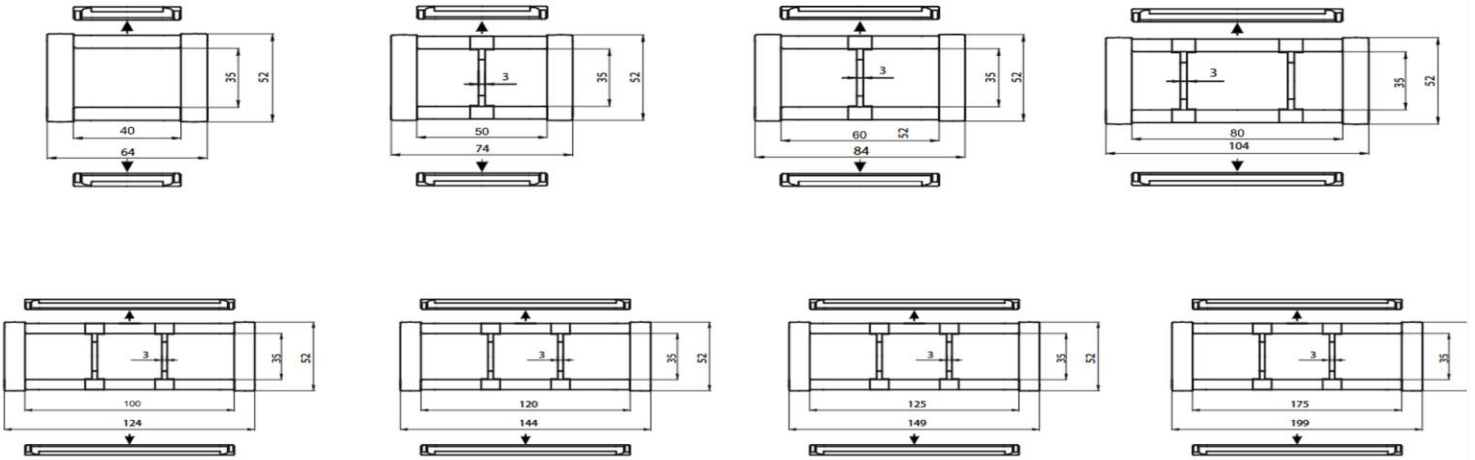

## Load Diagram :

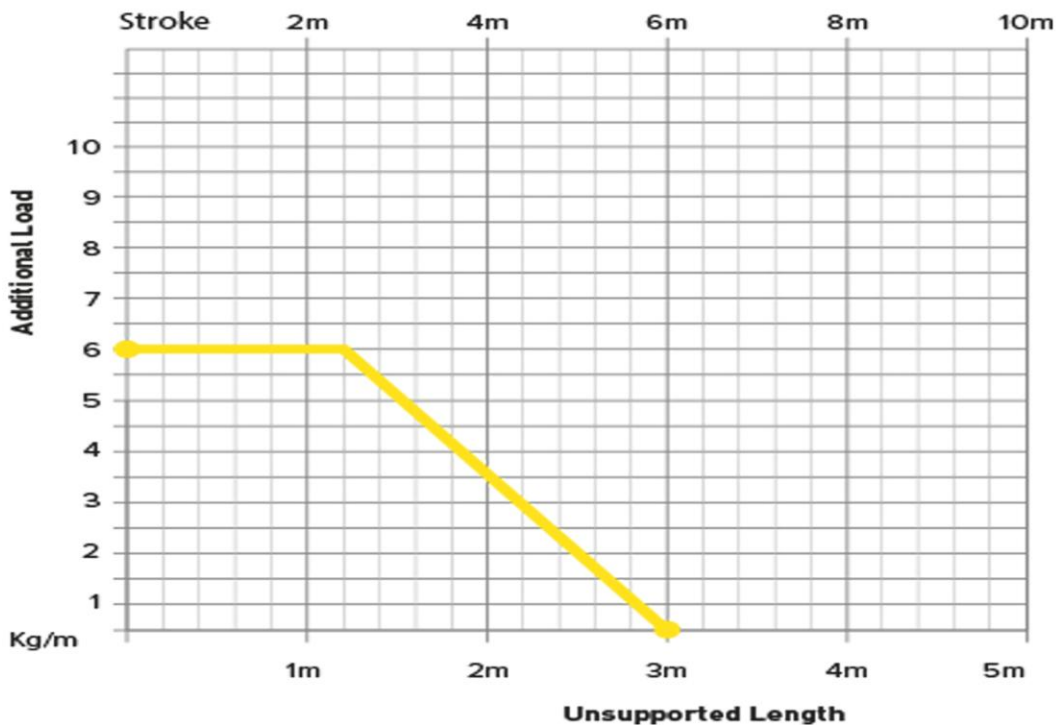

**CALL US**

021-33531249-

## PLASTIC END BRACKETS :

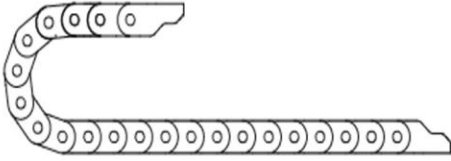

(End Brackets)

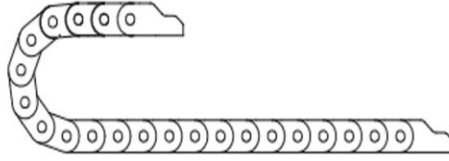

(End Brackets)

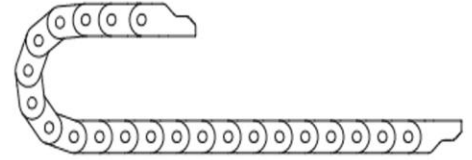

(End Brackets)

(Plastic End Brackets Connection)

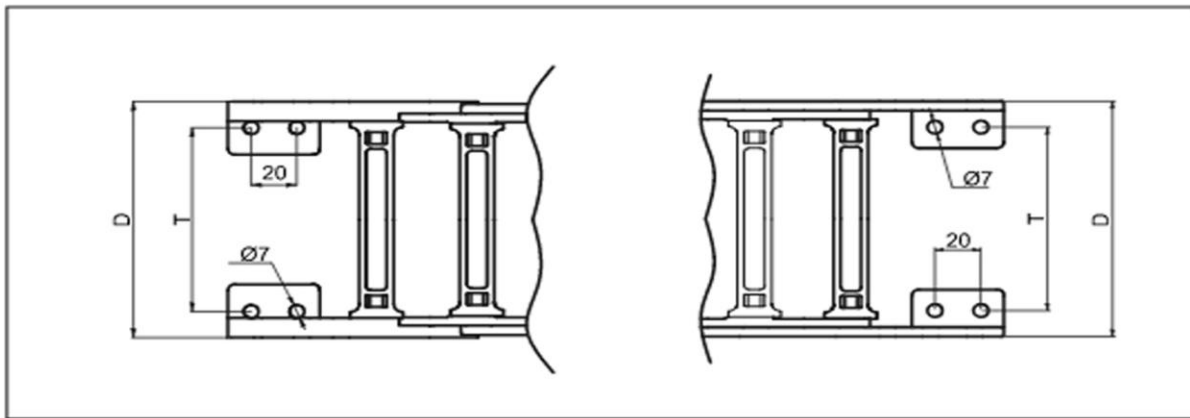

CODE	T	D
CK35 P 040	32	60
CK35 P 050	42	70
CK35 P 060	52	80
CK35 P 080	72	100
CK35 P 100	92	120
CK35 P 120	112	140
CK35 P 125	117	145





**DIVIDER :**

VERTICAL DIVIDER

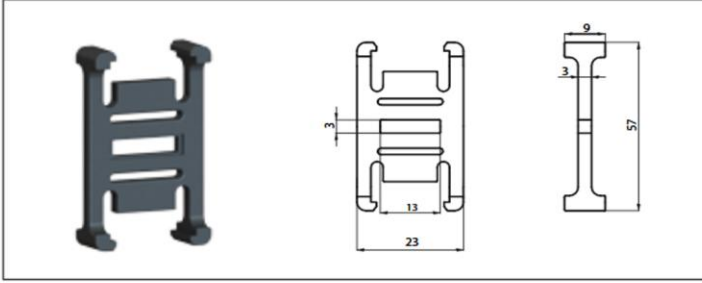

HORIZONTAL SEPARATOR

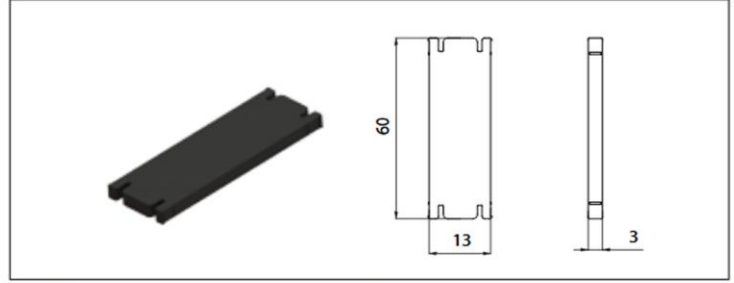

T	TİP / TYPE	UZUNLUK / LENGHT (mm)
	CK YSP 060	60
	CK YSP 080	80
	CK YSP 100	100

**Use the Divider :**

You can separate the cable and hose from each other by using vertical and horizontal divider



## ASSEMBLY :

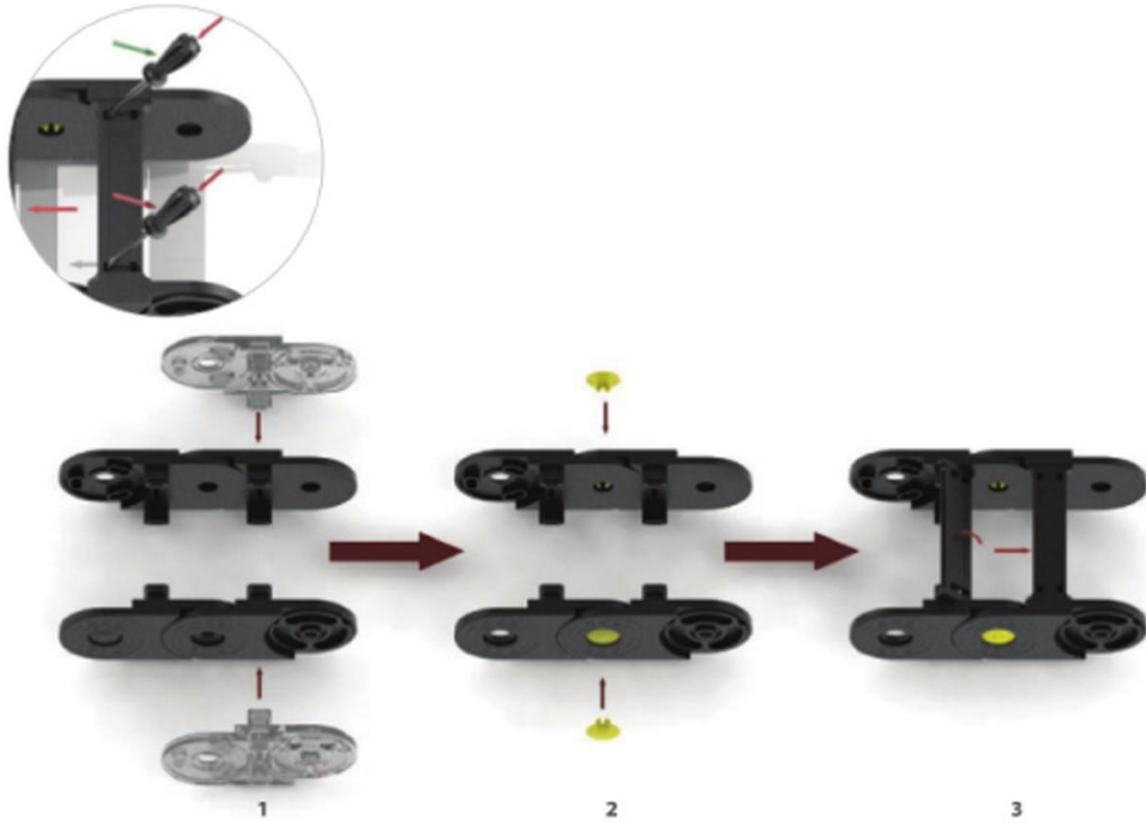

## DIASSEMBLY :

